

*ADAPTED SCHOOL WORKSPACES FOR STUDENTS
WITH SPECIAL NEEDS*

A Resource Guide for Planning



**BRITISH
COLUMBIA**

Ministry of Education,
Skills and Training

*ADAPTED SCHOOL WORKSPACES FOR STUDENTS
WITH SPECIAL NEEDS*

A Resource Guide for Planning

1997

Acknowledgements

The Special Programs Branch of the Ministry of Education, Skills and Training gratefully acknowledges the following individuals for their contribution to the planning and development of this resource guide.

Marilyn Cram, Project Leader	School District No. 33 (Chilliwack)
Debra Mackie	School District No. 33 (Chilliwack)
Ian Black	School District No. 38 (Richmond)
Tom Edwards	School District No. 38 (Richmond)
Dave Cooper	Sunny Hill Health Center (Vancouver)
Doug Ardron	School District No. 39 (Vancouver)
Daria McMorran	School District No. 39 (Vancouver)
Audrey Gibson	Queen Alexandra Centre (Victoria)
Susan Bonnel	Queen Alexandra Centre (Victoria)
Marguerite Horne	Variety Child Development Centre (Surrey)
Susan Pederson	School District No. 35 (Langley)

This project was undertaken by School District No. 39 (Vancouver) under the direction of Paul Carson (SET-BC). The Ministry also acknowledges the contributions of the many BC educators and therapists who responded to the Adapted Workspaces Questionnaire.

Contents

SECTION 1	INTRODUCTION	9
	• Purpose of the Resource Guide	11
	• Who Needs an Adapted Workspace?	13
SECTION 2	THE PLANNING PROCESS	15
	• Guiding Principles	17
	• Steps in the Planning Process	18
	• Roles of Team Members	22
	• Strategy Tips for Planning	27
SECTION 3	CASE STUDIES	31
SECTION 4	DESIGN SOLUTION IDEAS	43
	• Seating and Positioning	45
	• Desktops and Tables	52
	• Storage and Space Saving Ideas	59
	• Accommodating Computers and Other Technologies in the Workspace	63
	• Adapted Workspaces Across the School	69
SECTION 5	APPENDICES	71
	• Appendix A: Resources	73
	• Appendix B: Observational Checklist	79
	• Appendix C: Adapted Workspaces Planning Form	81
	• Appendix D: Designing an Adapted Workspace	83

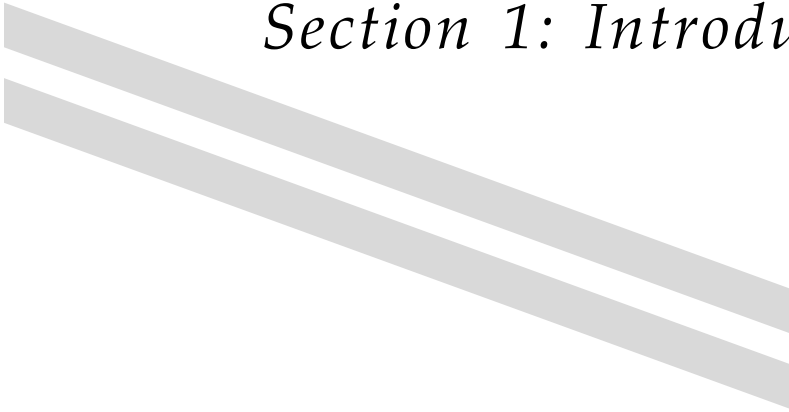

Section 1: Introduction

Introduction

PURPOSE OF THE RESOURCE GUIDE

Students with special needs may require a variety of adaptations to maximize their learning and participation in school. These adaptations may be in the materials used for instruction, the teaching strategies, or in the classroom environment. Regular classroom furniture such as traditional desks, tables, chairs, or laboratory stations may not be appropriate to facilitate success for some students. They may need accommodations such as adapted workspaces to support their learning.

Planning the appropriate workspace for a student with special needs, like other types of accommodations and support services, must be carried out in a careful, collaborative manner based on the particular student's strengths and needs. Adapted workspaces can be one of a variety of interventions planned as part of the overall Individual Education Plan for a student.

Adapted School Workspaces for Students with Special Needs: A Resource Guide for Planning is intended as a resource to facilitate the development of appropriate adapted school workspaces for students with special needs. It can be used as a tool by planning teams to guide the process. The same process can be applied to planning workspaces for students in other settings such as work experience placements in the community. Similar planning processes could be used in post secondary or employment settings.

This resource guide contains information on the types of students who might need an adapted school workspace. It covers the process which should be used to plan collaboratively the most effective workspace for an individual student. It outlines the roles of planning team members and some possible strategies which might be used

during this planning process. The resource includes case studies with workspace examples for districts or schools to consider. Some of these design solutions include adapted seating and positioning, adapted desks and tables, functional storage ideas, and suggestions for accommodating computer technology. The appendices contain reproducible forms to facilitate planning and record keeping and resource lists to help in locating manufacturers and suppliers of adapted workspaces or elements included in adapted workspace designs.

Much of the information for this resource guide was based on feedback from professionals with a variety of backgrounds gathered through a questionnaire circulated in 75 British Columbia school districts. Participants included school administrators, resource teachers, SET-BC District Partners, teachers of the visually impaired, speech and language pathologists, physiotherapists, occupational therapists, and school district maintenance personnel. Information was also gathered through consultation with Sunny Hill Health Centre, Children's Hospital in Vancouver, and Queen Alexandra Centre in Victoria. The information was compiled and developed into this resource guide by School District No. 39 (Vancouver) and staff at SET-BC (Special Education Technology-BC).

WHO NEEDS AN ADAPTED WORKSPACE?

Students with a variety of physical needs may require adaptations to their school workspaces. The design and quality of workspaces can make a significant contribution or present a serious hindrance to their ability to learn and develop their potential. This is true both in regular classroom environments and other locations in schools. Students who need adapted school workspaces will likely continue to need adaptations in the workplace for work experience placements. The same principles and planning processes can be applied in a variety of educational settings including post secondary environments.

Students may need adapted workspaces in school so that they can gain access to optimal learning situations and the greatest benefit possible from educational programs. These adaptations can provide greater comfort and safety than traditional desks, tables, or chairs in classrooms. They can increase the quality of movement and posture, improve visual/motor functioning and sensory processing, and increase independence. A functional adapted workspace can also help a student develop social skills and appropriate behaviour.

School staff such as the classroom teacher may first notice clues that a student could need adaptations to the workspace. It may appear that the student

- can not maintain posture in the desk,
- seems to be in an odd or uncomfortable position,
- does not participate in activities because of positioning,
- can not access computer or other technology effectively,

- has trouble communicating with peers or teacher because of seating or positioning,
- tires easily because of position challenges, or
- needs assistance to access materials, limiting independence.

Students who need adapted school workspaces may be students with multiple disabilities, students with physical disabilities, students with visual impairments, students who are deaf or hard of hearing, or other students who require accommodations to optimize their learning and participation.

Section 2: The Planning Process



The Planning Process

GUIDING PRINCIPLES

The planning for adapted school workspaces for students with special needs should be guided by some important general principles:

Adapted Workspaces should

- provide safety and comfort for the student,
- function as efficiently and as economically as possible to meet the student's needs,
- promote independence as much as possible, and
- facilitate appropriate interaction with peers and teachers.

These principles apply equally to workspaces designed to function in the school setting and workspaces required beyond the school environment such as work experience settings and other aspects of the student's educational program.

Steps in the Planning Process

From the stage when the need for adaptations to a student's workspace is first identified to its actual fabrication or purchase, careful planning should take place. The process should include gathering and sharing information, discussion, collaboration of a variety of people with specialized knowledge and skills, and team work to ensure that the planning is effective. Taking the right steps will ultimately result in a workspace that is safe, functional, and comfortable for the student and will ensure that the workspace enhances learning.

STEP ONE: ASSEMBLE THE PLANNING TEAM

The classroom teacher, resource teacher, therapist, or student may be the first to become aware that adaptations to a student's workspace are needed. A procedure for bringing such a concern forward to begin the planning process should be established in the school or district. In some cases, the appropriate beginning will be a referral to the school based team. In others, a meeting to develop the student's Individual Education Plan (IEP) will be the right forum. In some schools, a referral to district based administrative staff or district resource person will be an appropriate beginning. Regardless of the procedure which applies locally, it should next signal the gathering together of a team of people who can bring their particular expertise to bear on solving the workspace problem.

The section *Roles of Team Members* (pp. 22-26) describes possible team members and what each can contribute to the planning process. The nature of the student's needs will determine the kinds of skills and perspectives that should be brought together for the team.

STEP TWO: ASSIGN A TEAM LEADER

Feedback from school district personnel has emphasized the importance of leadership in the team. The group should choose a person who will take on the responsibility of planning team meetings, keeping records of discussions and decisions, and ensuring that plans are implemented. The designated leader could be the classroom teacher, resource teacher, physiotherapist, occupational therapist, or other specialist teacher such as a teacher of students with visual impairments.

STEP THREE: USE COLLABORATION TO PLAN THE WORKSPACE

Another feature of the planning process which was emphasized in district feedback is the importance of collaborative teamwork. The team should jointly clarify the scope of its work and ensure that all team members are able to fulfill their roles effectively. As a group, the team needs to decide how to go about analyzing the problem and arriving at possible solutions. These activities may prove effective:

- Circulate the section Roles of Team Members (pp. 22-26) for the first team meeting to ensure that all team members are clear about the roles they will play in the development of the student's adapted workspace.
- Begin an analysis of the student's workspace needs. The team may decide to use the *Observational Checklist, Appendix B* (p. 79) as a guide for this process. This form can help the team gain an accurate understanding of the student's school environment, for example, the demands for storage or access to computer technology equipment.

- Discuss the student's abilities and constraints and their implications for the workspace. The *Adapted Workspaces Planning Form, Appendix C* (pp. 36-38) can be a helpful tool to provide a framework for the team's discussions.
- Brainstorm the possible options to meet the student's needs and consider the advantages and disadvantages of each idea from the point of view of its functionality, safety, availability, cost, and teacher or student preference.
- Decide on basic workspace features and design. Section 4: *Design Solution Ideas* (pp. 45-69) has suggestions to assist the team.

STEP FOUR: PROVIDE THE ADAPTED WORKSPACE

Once the general plan is made, the details of actually providing the workspace still remain. This may include measuring, drafting, modifying existing equipment or furniture, and/or purchasing items. The form *Designing an Adapted Workspace, Appendix D* (p. 83) can be used to record information at this stage in the process. Choices to be considered in fabricating or purchasing the adapted workspace are also included in Section 4 of this guide.

Two case studies in this resource (pp. 33-42) provide examples of the decision making steps that took place in order to create the most appropriate work spaces for the students involved.

APPENDIX B: OBSERVATIONAL CHECKLIST

This form provides therapists with a comprehensive screening checklist to complete when called upon to provide the team with information regarding a student's workspace.

APPENDIX C: ADAPTED WORKSPACES PLANNING FORM

This form can provide a framework for the decision making process. The project leader should take responsibility for completing this form as a record of the team meeting.

Roles of Team Members

The Planning Team responsible for developing an adapted school workspace for a student may divide the activities and responsibilities in a variety of ways. These may vary from district to district or educational site to site. The following are some suggestions for consideration in delineating roles for possible members of the planning teams. Teams should ensure that the views of the student and perhaps the parent are well represented during the planning.

PROJECT LEADER

- Ensure that the appropriate people are involved in the team meetings
- Organize and chair the meetings
- Coordinate the development of the plan for adapted workspace and ensure that it is compatible with the goals for the student in the Individual Education Plan
- Facilitate group decision making and clarify duties and commitments of team members to implement parts of the plan
- Ensure that district procedures are followed for the planning, fabricating, or purchasing of equipment or furniture
- Ensure that records of the meetings and decisions are kept and distributed to team members and other relevant people
- Monitor the process and ensure that the plan is carried out

CLASSROOM TEACHER

- Describe the student's individual education goals (i.e. academic program and functional life skills program)
- Describe the expectations of the class such as seating arrangements, group work/cooperative learning situations, and mobility demands
- Help determine the most effective classroom seating placement for the student
- Help determine alternate storage facilities within the classroom for items such as books, laptop computers, desktop computers, printers, or Braille printers
- Promote acceptance of diversity, particularly when the student's adapted workspace may appear different from classmates' desks
- Provide opportunities for the student to learn to use the adapted workspace as independently and safely as possible (how to open drawers or access books)

SPECIAL EDUCATION TEACHER

- Supplement the teacher's description of the student's individual goals
- Provide information on the student's long term educational goals
- Share information on the student's potential educational placement in preparation for an anticipated transition to another setting

- Help assess the student's use of technology (how frequently the student uses technology, at what times of the day and during which activities or subjects)
- Share information on any medical conditions that may affect the design of the adapted workspace or seating arrangements (examples include visual impairments, hearing impairments, and seizures disorders)

PHYSIOTHERAPIST AND OCCUPATIONAL THERAPISTS

- Share information about the student's positioning and posture needs
- Assess the student and inform the team about the student's motor abilities and requirements (i.e. hand function, reach, keyboarding skills, computer accessing implications, material storage implications)
- Provide information about the student's present and/or new equipment (i.e. seating inserts, splints, standing frames, walkers, wheelchairs)
- Provide information regarding any pending medical procedures for the student (i.e. medical re-evaluations, orthopaedic surgery)
- Share technical expertise regarding adapted workspaces (i.e. catalogues, photographs, recommended designs and modifications)
- Work closely with local designers and fabricators, when the adapted workspace is to be built, to ensure that the workspace is functional, safe and cost effective

TEACHER OF STUDENTS WITH VISUAL IMPAIRMENTS

- Share information on the student's visual impairment
- Share information on the classroom implications of the student's visual impairment (i.e. seating, location of desk, and workspace surface)
- Share information on the student's technology and the implications for accessibility and storage (Braille readers, Braille printers, and computers)

TEACHER OF STUDENTS WHO ARE DEAF OR HARD OF HEARING

- Share information on the student's hearing impairment
- Explain the classroom implications of the student's hearing impairment (i.e. location of the desk)
- Share information on the student's technology and the implications for accessibility and storage

SPEECH/LANGUAGE PATHOLOGIST

- Explain the student's communication abilities as well as equipment information (i.e. augmentative communication devices, technology and materials for communication, issues of accessibility and storage)

DESIGNER/FABRICATOR

- Share expertise in the designing and fabricating of adapted workspaces
- Provide the team with recommendations for specific adapted workspaces based on the team's requests (i.e. recommended construction material, hinges, and pivot systems)
- Work closely with therapists during the design, measurement and construction phase, identifying special equipment storage issues and safety and accessibility concerns
- Recommend whether the adapted workspace should be purchased or fabricated locally, based on cost factors and other constraints

STRATEGY TIPS FOR PLANNING

During the development of this resource guide, practitioners across British Columbia were asked for suggestions which could assist others in planning adapted school workspaces for their students.

In general, they said that adapted workspaces should position the student in the way that best facilitates learning and fosters inclusion in the classroom activities.

Teams should involve classroom teachers and students themselves in the planning process, paying particular attention to the preferences of classroom teachers and students. For example, students often prefer desks that are as close to the same size as desks used by their peers. Teachers often want the workspace to be easily moved around the classroom for group work activities. The students and staff who use the workspaces every day should have an opportunity to suggest preferences about their appearance such as the type of materials, colour, or shape. Meeting such preferences as much as possible can enhance the effectiveness of the workspace because it will be more readily accepted by its users.

TIPS FOR TEACHERS

During the planning stages, school staff should be sure to include information about the school environment which will affect the design and enhance the effectiveness of adapted workspaces. After a workspace is provided, the classroom teacher can play an important role in determining how well that workspace is integrated into the classroom environment and how functional it proves to be for the student.

During the planning

- Consider extended storage facilities that might be needed (accessible and convenient for the student)
- Ensure that the power supply is planned to work effectively with the student's workspace needs

After the workspace is provided

- Ensure that the student has an opportunity to learn about the various safety, storage and access features of the adapted workspace
- Locate the student's adapted workspace in the best position in the classroom (i.e., allows for peer interactions, provides good visibility of the teacher, minimizes negative affect on any classroom activity)
- Make positive comments about the student's adapted workspace and model acceptance of it so the student and classmates learn to accept a workspace that looks different

TIPS FOR PHYSIOTHERAPISTS AND OCCUPATIONAL THERAPISTS

- Analyze the school environments to ensure that the planned workspace is easily accommodated and functional in the setting
- Think safety and stability for all aspects of the workspace and ensure designs comply with safety standards
- Focus on simplicity and adaptability (A height adjustable desk is often a therapist's first choice because it is practical, inexpensive, and most accepted by school staff and students.)
- Keep ergonomics and function in mind
- Remember that each situation is unique and consequently takes time to plan
- Work on a team which includes all members whose contributions are essential (Failing to include the fabricator can lead to unnecessary expense and frustration later in the process.)
- Use pre-fab trials when possible
- Contact others for additional ideas, such as OT/PT mentors and/or SET-BC staff
- Seek input and support from local / district fabricators

TIPS FOR DESIGNERS/FABRICATORS

- Recognize that their presence as experts in design and construction of adapted workspaces is valued, particularly in complex situations
- Consider adapted workspaces that are adjustable (height and sometimes width) so that student growth can be easily accommodated

- Ensure that all team members are aware of options to meet safety issues related to the adapted workspace:
 - ✓ durable structures, 'earthquake proof' design
 - ✓ anti-tipping struts or adequate base size to support student weight and equipment, especially if the student leans on the desk to stand up and transfer to a chair or walk
 - ✓ adjustable height devices which pivot and adjust to prevent collapses
 - ✓ elimination of pinch points and sharp edges
 - ✓ toe locking castors to prevent unintended movement
 - ✓ parts which are designed to minimize "fiddling" by the student, thus minimizing breakage, lost pieces, and student injury
- Become aware of commercially produced adapted workspaces to help determine whether it is more feasible to purchase, alter or fabricate an adapted workspace
- Remember that useful parts for adapted workspaces are often found in
 - hardware stores,
 - building supply stores,
 - recreational vehicle supply stores,
 - computer and office supply stores,
 - music stores, or
 - plexiglass fabricators

TIPS FOR SCHOOL DISTRICTS

- Create an effective and equitable process for funding the purchase or creation of adapted workspaces for students with special needs
- Ensure that school district designers/fabricators and therapists have adequate time and budget allotments to meet these ongoing needs

Section 3: Case Studies

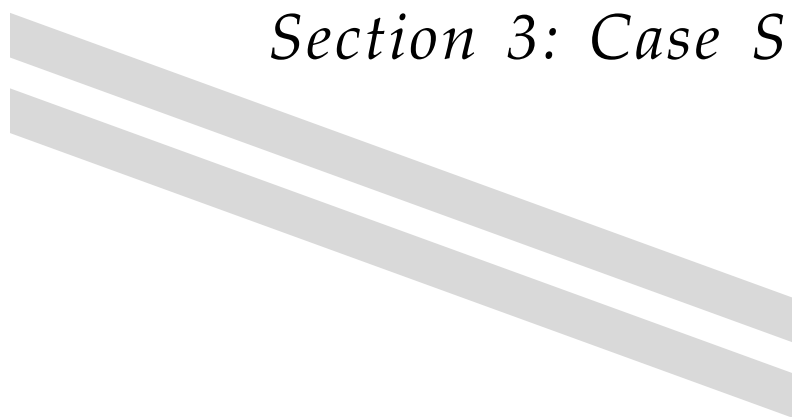

DRAFT

DRAFT

CASE STUDIES

CASE STUDY #1

- *Lynette*

Lynette is a nine year old student with Turner Syndrome, a genetic disorder resulting in physical anomalies and learning disabilities. As with other girls having Turner Syndrome, Lynette is very short and has visual-perceptual difficulties. She has difficulty with balance and coordination as well as significant trouble with fine motor skills.

When Lynette sits in a regular school desk, her feet do not touch the floor, and she struggles to maintain her balance. The desktop is also too high for her to work with ease. Her discomfort and tentative balance further detract from her ability to attend to learning and distract her from her school tasks. Lynette uses a desk top computer on loan from SET-BC for written assignments.

Assembling the Planning Team and Assigning a Team Leader

Lynette's planning team included Lynette and the same people who made up the Individual Education Planning Team: her classroom teacher, her mother, a physiotherapist, and the school based resource teacher who acted as the leader of the team. Before the first team meeting, the resource teacher used the *Observational Checklist* (p. 35) to begin assessing Lynette's needs for an adapted school workspace.

Planning the Workspace

Analyzing Lynette's Needs

Lynette's team met to discuss Lynette's difficulties and possible solutions. The team looked at Lynette's physical abilities, mobility, motor abilities, learning difficulties affected by workspace issues, and classroom demands for group work. They decided that she needed modifications to her workspace to ensure her stability and proper posture, including adjustments to the height of her seat. They also agreed that she needed a separate station for intermittent computer use.

The team recorded information from their meeting on the *Adapted Workspace Planning Form* (p. 36-38).

Deciding on Solutions

The team discussed several possible modifications of the workspace to meet Lynette's needs:

- increase the height of her seat so she would have easier access to her desktop, which would then be the same height as the other students' desks,
- provide Lynette with a wooden box-like footstool so that she would be able to maintain the correct sitting posture, and
- provide another table for her computer, close to her desk, but not on her desktop, since she is only using the computer for a portion of the school day.

They used the form, *Designing an Adapted Workspace* (p. 39) to record measurements, dimensions and features of Lynette's workspace.

Fabricating the Workspace

The resource teacher worked with the school district maintenance department to design adaptations for Lynette's chair, a footstool, and an additional table was obtained from the central supply department. The maintenance staff completed the work and delivered it to Lynette's classroom teacher.

DRAFT

Appendix B

Observational Checklist

This form should be completed by the project leader coordinating the development of the adapted workspace. You are encouraged to consult with those involved with the student to establish an accurate understanding of the student's environment.

Student: Lynette Ashton School: A.B. Jones Elem
 Completed by: Bill Pearson Date Completed: 9/11/21
 Please check (v): Initial Observation Review

1. Where in the classroom, is the student's workspace located? at the front of the room to the right of the teacher's desk

2. Describe the student's current seating. (noting posture, positioning, etc.) Lynette is short in stature and while seated at her desk, her feet do not touch the floor

3. Describe the student's current workstation or workspace. modified student desk with a tabletop surface area that is insufficient.

• Desktop height: 22" measurement appropriate too low too high
 • Desktop space (area): 23" x 18" measurement appropriate too small too big

4. Describe the student's use of and access to technology. (include access to power source) student has the use of a desktop computer with Intelikay adapted keyboard.

5. Describe student's access to storage (noting whether storage is adequate and if it provides independent access) currently all materials are stored in a shelf unit at the front of the classroom

6. List any concerns regarding motor demands on the student (such as fatigue, access, etc.) lynette does tire easily and lacks good balance and coordination.

7. Can the student see the teacher, classroom presentations, materials, peers? yes no

8. Does the workspace (location, size, etc.) facilitate peer interaction? yes no

Appendix C

Adapted Workspaces Planning Form

This form should be completed by the project leader coordinating the development of the adapted workspace. You are encouraged to identify and invite all those involved with the student who will play a key role in the design of an appropriate workspace.

Student: Lynette Ashton School: A.B. Jones Elem
 Meeting date: 9/12/02 Project Leader: Bill Pearson

General Information

Team members involved with this student and attending the meeting.		
Name:	Role/Position:	Telephone:
Rob Jones	Classroom Teacher	387.2424
Heather Smith	SLP	387.9291
Sarah Ferguson	Resource Teacher	387.2424
Peter Tolmin	Principal	387.2424
Tricia Ashton	Parent	354.6660
Don Ashton	Parent	354.6660
Bill Pearson	Occupational Therapist	388.2526

Planning Discussion

For each of the following attributes, first describe the student's level of ability. Second, record the discussion with respect to the *Implications for Workspace and its Location*.

- Physical ability
- Mobility and seating
- Motor abilities and constraints
- Vision
- Hearing
- Technology

Physical ability: (mobility, movement, posture, etc.)

Lynette is short in stature and has poor balance and coordination.

Implications for Workspace: Once seated, Lynette requires a footstool for her feet. She also requires a chair with arm rests to provide stability when sitting for long periods of time.

Appendix C

AWS Planning Form

... 2

Mobility and seating:

Difficulty maneuvering through the rows of classroom desks

Implications for Workspace: Location of Lynette's work space at the front of the room with very little in the way of obstacles will be very helpful.

Motor abilities and constraints:

Lynette does fatigue easily so she requires a certain degree of support while at the work station

Implications for Workspace: She is using a large adapted keyboard for many educational activities. Angling the desktop for all activities will be a useful adaptation.

Vision:

Some visual-perceptual difficulties

Implications for Workspace and its Location: The design and current location plan accommodate the requires for Lynette's work space.

Hearing:

Not Applicable

Implications for Workspace and its Location:

DRAFT

Appendix C

AWS Planning Form

...3

Educational Program Considerations:

Student's Educational Goals

Lynette's program is modified only marginally. She uses her computer for written output. With the aid of access software like Co:Writer and Write:Outloud she receives good support in the writing process. The enlarged keyboards assists with her fine motor problems for a variety of computer input activities.

Classroom Curricular Demands (cooperative learning, other group work, lab work, courses in other classrooms).

Lynette is a very popular student who engages classmates in a very positive manner. Often, group assignments are a very exciting opportunity for Lynette and as a result her workspace should accommodate the needs of small groups of students bringing their desks around hers.

Student will transition to:

Lynette will be at AB Jones Elementary for the next 3 years. This workspace will adequately meet her needs during this period of time. Both the chair and desk will have adjustable legs to adapt to her changing needs over time.

Appendix D

Designing an Adapted Workspace

This form is designed to assist school team members identify key design components for a student's custom workspace.

Student: Lynette Ashton School: A.B. Jones Elem

Person Completing This Form: Bill Pearson Date: 9/03/14

Write Your Own Measurements (✓):

1. Height: adjustable (from floor): 26" minimum height castors yes
 non-adjustable 30" maximum height: *locking no

2. Table Top Dimensions: 48" wide, 28" deep

liftable for storage under the desktop

slant top with angle adjustments, specify degrees 25° 1/2 split
 depth of storage (consider height of knees under the desk) right side

3. Cut-out: (to bring student closer to work surface and/or provide forearm support)

yes, -- if yes, sketch the shape of the cut-out: _____ width of cut-out

no _____ depth of cut-out

_____ total width of desk

Forearm support area: width remaining _____ left side _____ right side

4. Attachments: (monitor, keyboard, and storage components)

a) monitor stand: attached to the desk not attached to the desk

b) keyboard tray: yes no location: _____

c) side baskets for books and tools: yes no

right side left side

dimensions: 15" wide and the
depth of the table top

5. Other Features: * ensure that castors are locking

must have a piano hinge for angling
up the desktop and a locking stem
to ensure security of the desktop in the up
position.

CASE STUDY #2

- *Scott*

Scott is 12 years old and has athetoid cerebral palsy. He uses a power wheelchair and has the use of a laptop computer on loan from SET-BC. Scott has just moved from another school district and attends a regular grade 6 class at his neighbourhood school. In consultation with Scott's former teacher, it was discovered that he used a modified table which was very different in appearance from other student desks.

Scott's new class is an active one with many opportunities for cooperative learning situations. Students move about the class and rearrange desks as they create their groups. Scott's wheelchair will not fit under the present desk top height. The desk top itself is large enough to hold a laptop computer but little else. When the computer is on his desk top, Scott is not able to lift up the top and access books from the normal storage compartment, nor can he retrieve books from an under-the-desk storage space if the desk top does not lift up. Scott uses the computer frequently during the school day, so he needs it to be easily accessible.

Assembling the Planning Team and Assigning a Team Leader

The team included Scott, Scott's mother, the classroom teacher, teacher assistant, special education teacher, physiotherapist and occupational therapist. The occupational therapist also filled the role of team leader.

Planning the Workspace

The team was anxious to make appropriate recommendations for Scott and to facilitate a smooth process for the creation of an adapted workspace for him. All team members agreed that Scott required an adapted work space. However, there were a number of constraints. His teacher did not want a large desk, nor one that was significantly higher than the other desks in the room. He felt these would exclude Scott from active

participation in many of the cooperative groups. Scott said that he wanted to be as much like the other kids as possible. Scott's mother wanted him to have as much independence as possible. The therapist added that the adapted workspace needed to be as functional as possible. The teacher and teacher assistant wanted Scott to be able to access stored materials such as books. They also wanted him to have easy access to the laptop computer. They team decided he needed an enlarged desk top designed to meet all of these requirements.

The occupational therapist brought several design samples of possible workspaces, including catalogues and photos. She presented 3 recommended designs and after much discussion and some further modification recommendations, one design was selected.

Fabricating the Workspace

The occupational therapist then met with the school district cabinet makers, and it was determined that they could build the workspace for less than the commercial cost. The occupational therapist and the cabinet maker then met again with Scott and shared the plan for the new desk. Scott repeated his request that it be as close as possible to the height of the other desks. They took several measurements to use in the final plans. Scott's adapted workspace was completed within a month.

DRAFT

DRAFT

Section 4: Design Solution Ideas

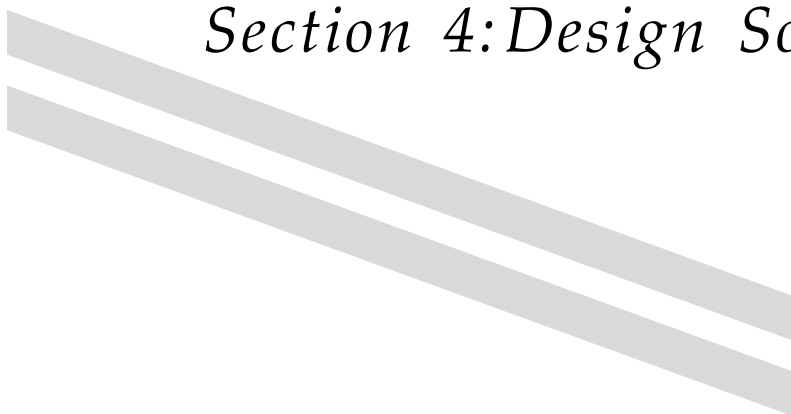

Design Solution Ideas

The purpose of this section is to provide therapists and educators with sample design solutions to consider when recommending fabrication or purchase of an adapted workspace for a student.

The design solutions are presented in a logical order that is inherent in the planning and decision-making stages involved in creating adapted workspaces. The sequence presented in this section includes:

1. seating and positioning,
2. desktops and workspaces,
3. storage and space saving ideas,
4. computers and other technologies, and
5. workspaces across the school

Possible design solutions in each area follow a continuum from basic to complex design. These start with relatively minor adaptations to regular workspaces, progressing to significant modifications, and could result in the development of highly specialized and customized workspaces.

1. SEATING AND POSITIONING

Safe and comfortable seating is essential and should be the first consideration when designing an adapted workspace. The first step in this process may involve simple solutions such as footstools and adjustments to present classroom chairs.

Chairs can range from adjustable height with supports and straps to commercial or custom designed scooter chairs. A specialized scooter chair may also include tilt-in-space features that will permit adjustable settings for the student in a variety of workspaces.

FOOTSTOOLS

Footstools may be fabricated or purchased commercially, including adjustables. A number of school teams responding to the questionnaire indicated their school districts have footstool designs that secure to the chair and/or desk to provide a higher degree of safety.

Some design features to consider include

- sliding bolt fasteners fit into the holes in the bottom panel of the footstool and secure it to the chair,
- simple adjustable height which can be changed to meet the student's needs or growth, or
- footstraps may be added to aid in secure the student's legs in a proper balance and support position.

Figure 1-1 • Footstool Design from Linda Thiessen, OT (Prince George)

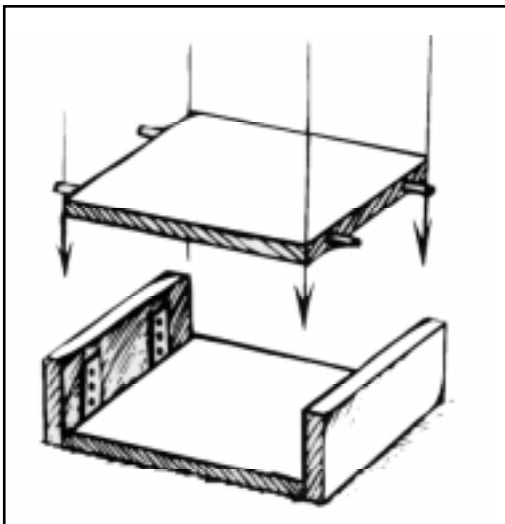

This custom designed footstool illustrates the ease of adjustability.

ADJUSTABLE CHAIRS

Adjustable height chairs are commercially available or modifications may be made to existing chairs. Adjustments to a student's chair may be required to improve the student's positioning at the desired workspace. Design teams have found that an insert can fit into a custom chair. This helps the student maintain comfortable and correct posture and yet allows the student to sit at a regular or slightly modified desk.

Figure 1-2 • Student Chair with Obus - Back Rest

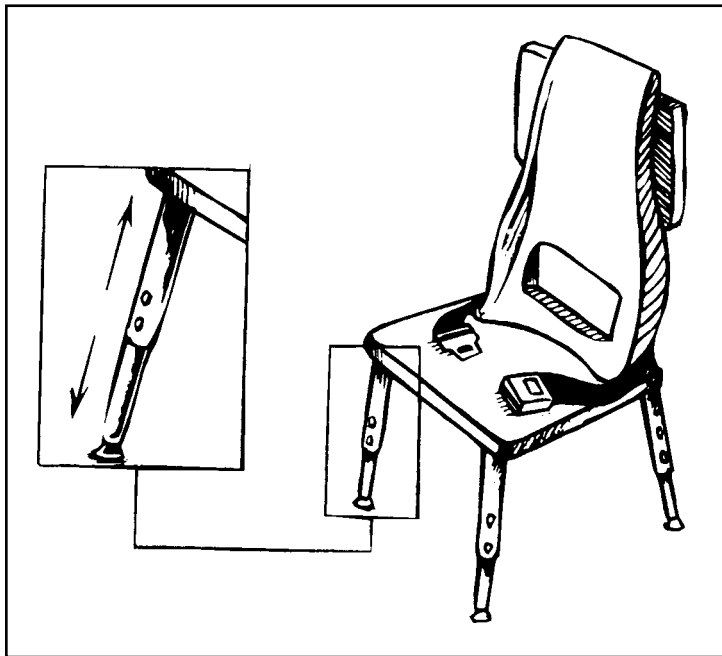

Figure 1-2 illustrates the ease with which modifications can be made to commercially available school chairs. For example, additional items, like a foam back support, or a lap style seat belt provide simple solutions that enhance position and safety. These additions also demonstrate minimum alterations on the continuum of adapting for seating needs.

If a student requires more support or unique mobility needs become a factor, there are a number of adjustable seating systems available commercially.

Figure 1-3 • Mobile Adjustable Chair

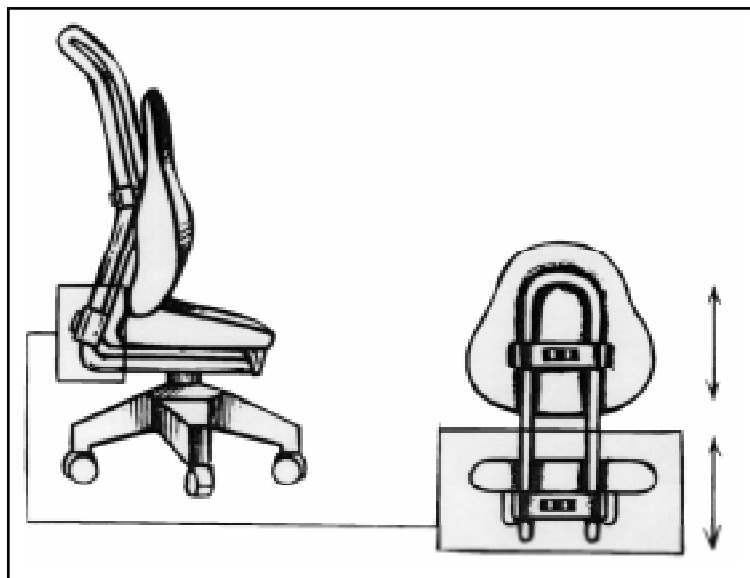
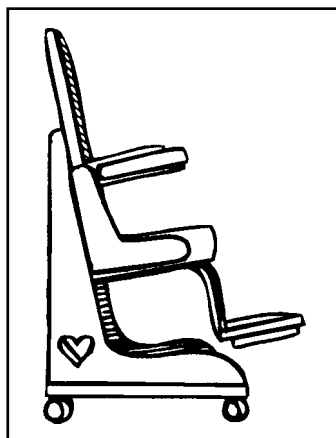

Figure 1-4 • Specialized Seating Needs

a) Positioning Chair



b) Posture Chair with Tray Table

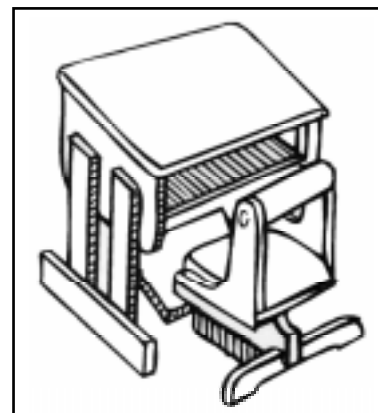

Figure 1-5 • Bolster Seat

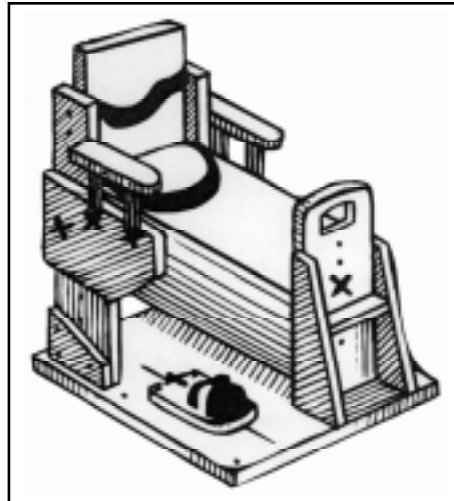
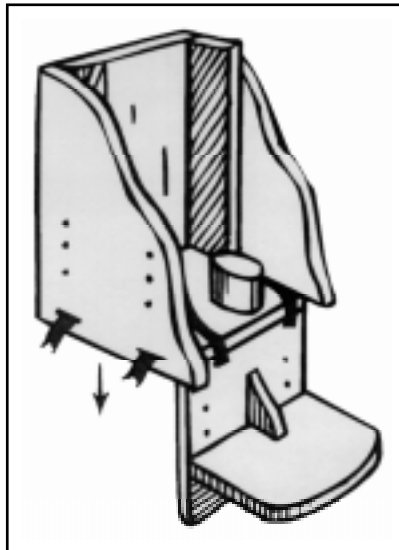
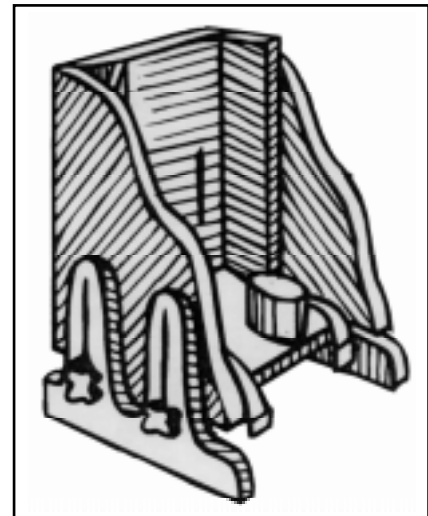

Figure 1-6 • Booster Seats

a) Booster Seat - insert model



b) Booster Seat - floor model



SCOOTER CHAIRS

Scooter chairs are designed to allow students to fit their knees under a Primary table or desk, so they can sit at the table or desk like their classmates. Once the student is positioned comfortably in the chair, the wheels make it easier to roll the student up to the workspace.

Several examples of fabricated and commercially available chairs are shown in the following figures. For more information about these products, please refer to the Resources Section of this guide for addresses of the suppliers.

A child may sit directly in a padded, custom design scooter chair or the child's personal wheelchair insert may be fastened into the scooter chair. Figure 1-7 is a sketch of a wooden chair on wheels.

Figure 1-7 • Scooter Chair (custom built)

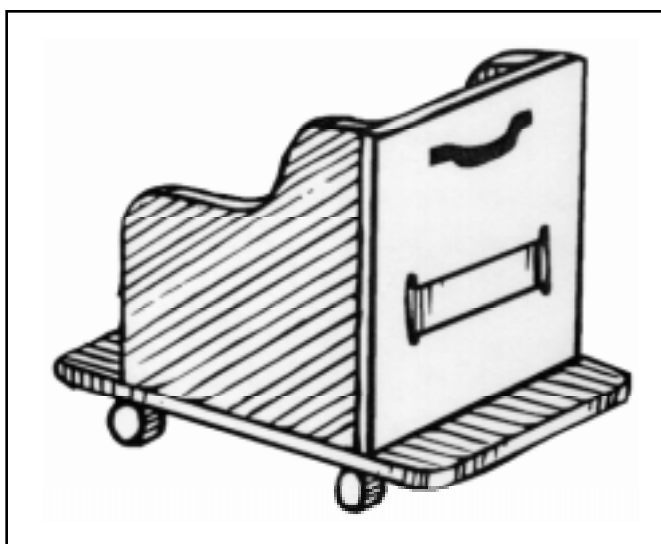

Variations to the scooter chair may include astride benches with or without wheels, The following suggestions need to be considered when designing a scooter chair:

- toe-locking castors to prevent the chair from moving after the student has been properly positioned, and
- door handle grips for easier handling of the chair when moving the student around.

Figure 1-8 is an example of a unique design that incorporates a number of features including a tray top work surface, adjustable size settings, tilting ability, and rollers for mobility.

Figure 1-8 • Mobile Adjustable Tilt Chair

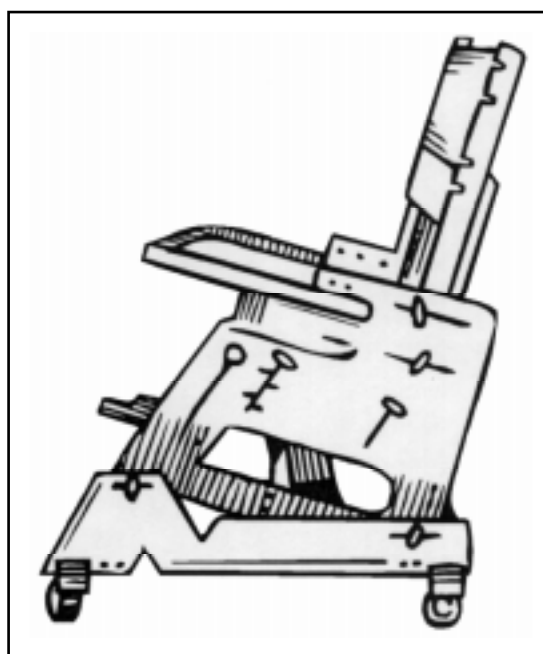

2. DESKTOPS AND TABLES

School districts can design and construct or order height adjustable desks and tables from a number of suppliers. The following illustrations show a variety of commercially available and custom designed tables and desks.

The kindergarten “cut-out” style height adjustable table in Figure 2-1 gives the table top graduated heights between 38 and 58 cm. from the floor. Positioning the student in the “cut-out” provides the student with a greater degree of forearm support during tabletop activities.

Figure 2-1 • Cut Out Table

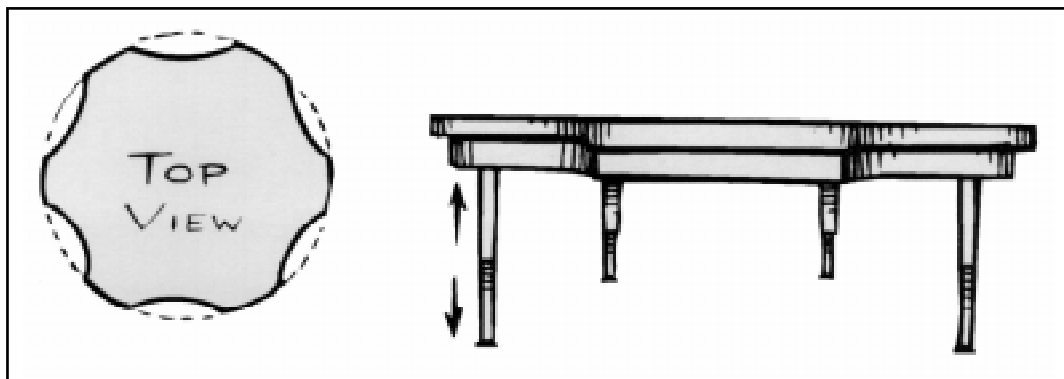

Figure 2-2 • Adjustable Height Desk
This “lift-lid” adjustable height desk is one example of a number of styles available.



CUSTOM DESKS DESIGNED BY SCHOOL DISTRICTS

APPENDIX D

Designing an Adapted Workspace
This form is designed to assist school teams members identify key design components for a student's custom workspace.

Student: _____ School: _____ Date: _____
Person Completing This Form: _____

Write Your Own Measurements (1/)

1. Height: adjustable (from floor) _____ minimum height _____ maximum height _____ castors yes no
 non-adjustable

2. Table Top Dimensions: _____ wide _____ deep
 liftable for storage under the desktop
 slant top with angle adjuster specify degrees _____
 depth of storage (consider height of knees under the desk) _____

3. Cut-out: (to bring student closer to work surface and/or provide forearm support)
 yes -- if yes sketch the shape of the cut-out: _____
 no

Forearm support area: width remaining _____ width of cut-out _____
depth of cut-out _____ total width of desk _____
left side _____ right side _____

4. Attachments: (monitor, keyboard, and storage components)
a) monitor stand: attached to the desk not attached to the desk
b) keyboard tray: yes no Inset: yes no
c) side baskets for books and tools: right side left side

5. Other Features: _____
dimensions: _____

School teams may decide to work closely with the carpenters in their own school districts to design and produce custom desk projects. For example, the Maintenance Department in School District No. 38 (Richmond) has collaborated with school staff on a number of occasions to design customized workspaces for Richmond students.

Appendix D provides school teams with a framework for designing a customized classroom workspace.

In some schools, planning and creating workspaces for students with special needs is carried out in the school technology education program. Outcomes in the curriculum for secondary technology education encourage design and fabrication of real and functional items. Schools and districts who want to consider this method of developing workspaces will need to be sensitive to existing employee/district collective agreements.

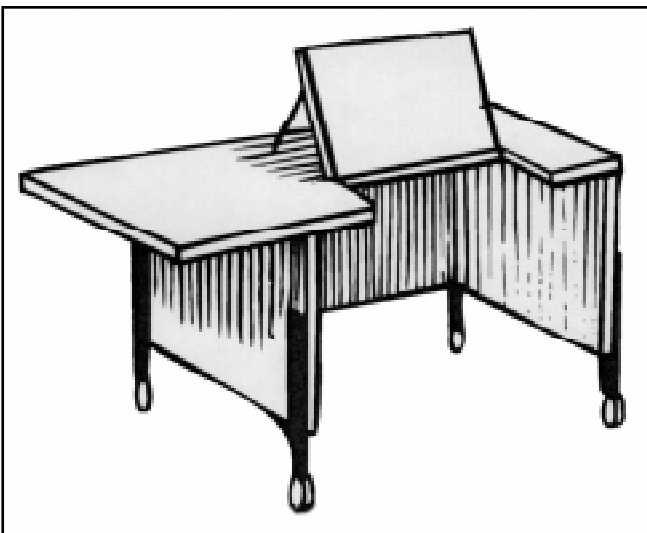

Figure 2-3 • Custom Desk Design
(Tom Black, Carpenter, School District No. 38 - Richmond)

This custom designed workspace illustrates a number of innovative features to meet the needs of the student. These features include a cut out table top, an adjustable angle desel, additional storage spaces for utensils, supplies, and books, and castors to allow for easy movement from classroom to classroom.

CUSTOM DESKTOPS WITH EASELS

Desktop easels can be attached to regular classroom desks. Height adjustable desks are preferred. These two are easy to attach and remove which makes them very practical for students moving to several locations during the school day.

Figure 2-4 • Custom Design (S.D. No. 33 - Chilliwack)

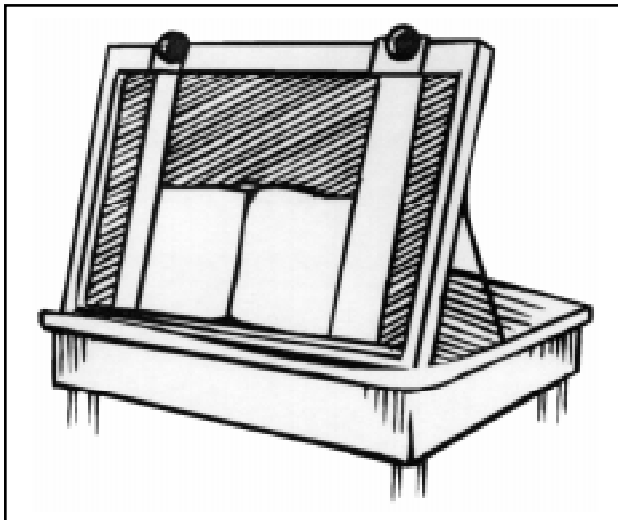

This desktop easel has guide bars that keep hard cover books fixed to the desktop. It also makes use of a blackboard surface for “chalk-in-hand” activities and, if desired, the use of magnets to hold paper activities in place.

Figure 2-5 • Custom Design (S.D. No. 33 - Chilliwack)

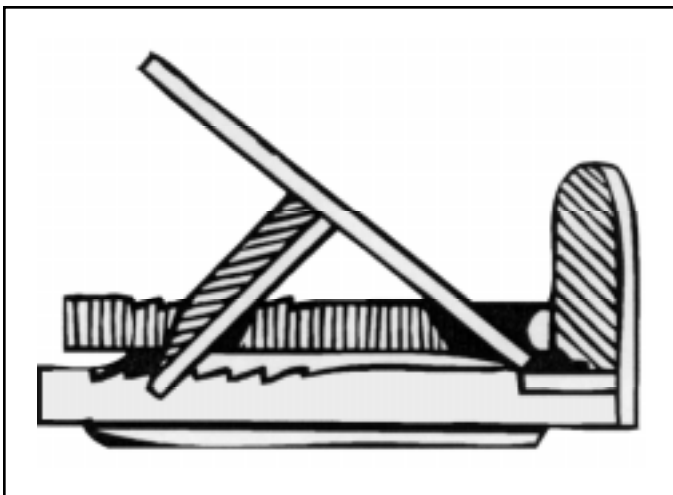

This custom easel desktop provides forearm support. The addition of the hinged supports ensures that the original desktop does not have to be modified or cut in any way. The flip-up style improves access to the desk and to supplies. All hinges are recessed on the underside of the work surface. For safety, a velcro strap can be used to fix the inclined easel in place on the standard desktop.

ADJUSTABLE TABLES

There are a number of ways to create height adjustable work tables. The less expensive method is by bolt adjustments similar to the height adjustable chairs and desks shown on pages 47 to 52. Other methods that allow staff and students to quickly alter the settings include hand crank design, hydraulic design, or electric design.

In situations demanding quick changes, where a variety of heights are required, ease of altering height is a factor in deciding which mechanism to select.

Figure 2-6 • Round Work Table



The hydraulic mechanism on the pedestal adjusts the height of the table easily, operating like a dental chair. This feature may be useful for a student requiring a variety of positions during the course of the school day.

COMMERCIAL ADJUSTABLE TABLES AND DESKTOPS

Some school districts order commercial desks and tables while others prefer to make their own depending on price, time available to fabricate, and costs of materials and labor. Examples are illustrated below.

Figure 2-7 • Height Adjustable Table

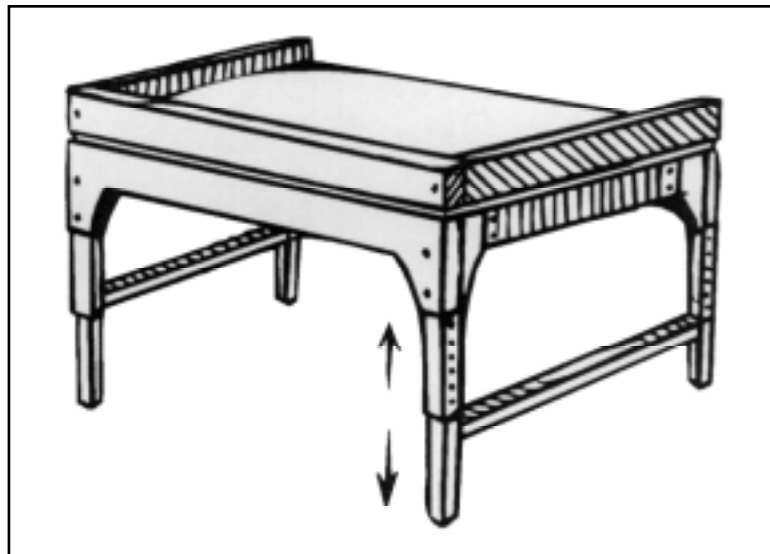
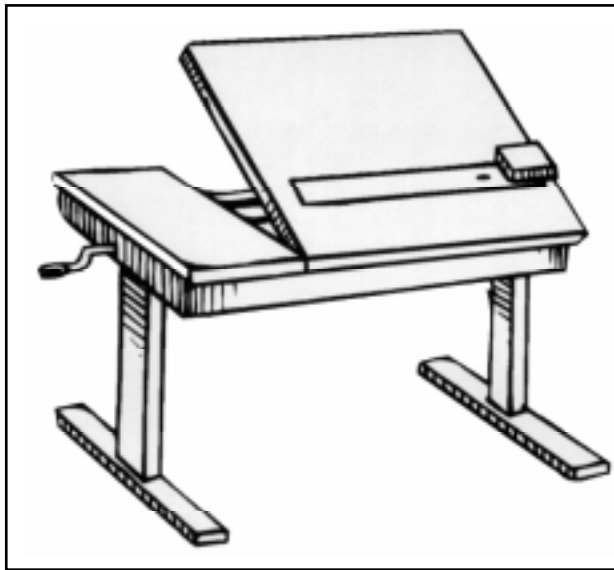
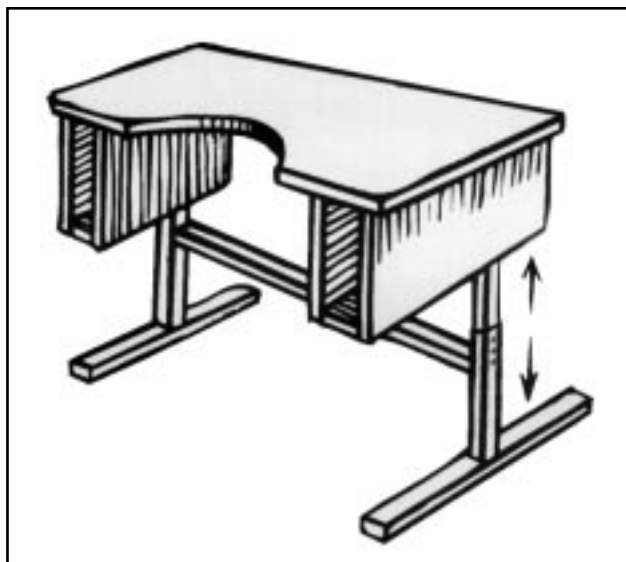

Figure 2-8 • Easel Split Desktop



If left or right handedness and/or vision needs which include impairments on one side require consideration, a partial easel may be the best choice for a desktop. In this model, the desktop height is also adjustable with a crank. Most suppliers will provide a right or left split model.

Figure 2-9 • Adjustable Classroom Desk



This desk illustrates a “made to measure” model which includes an individually designed cut out in the desk top and easily accessible storage spaces. Some commercial suppliers offer special orders for custom desktops, tables, computer tables, and other adjustable furniture to meet the special needs of students in school.

Figure 2-10 • Folding Mounting Arm

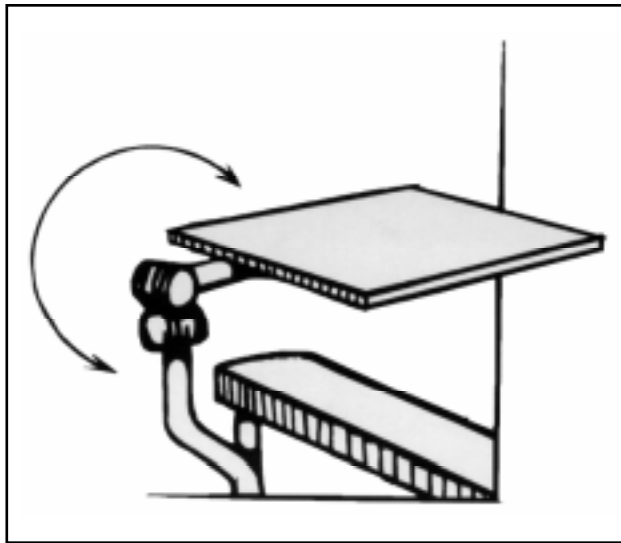

The best solution may be a folding mounting arm to which technology can be attached. This solution is a very portable and secure adapted workspace. However, the weight of the technology must be considered with the balanced weight of the student and his/her wheelchair.

3. STORAGE AND SPACE SAVING IDEAS

Easy access to supplies, storage of supplies, and security of equipment are all very important features of any workspace design. These features must be considered in the initial stages of planning the workspace in order to maximize the efficiency of the product.

School teams have offered a number of valuable suggestions for storage and space saving ideas. Taking the time to consider these important features in planning and designing a workspace can mean increased independence for a student, improved function of the workspace, and longevity of the equipment.

ATTACHING ADDITIONAL STORAGE

The initial step in determining the need for storage space is to look at ways of adding or attaching storage units to existing workspaces. Consider the following suggestions when deciding on what types of storage will be required:

1. Attach side baskets with a sliding drawer mechanism, if needed.
2. Attach side pouches made of wood, cloth, or plastic.
3. Purchase from office supply stores desk top bins and organizers for on top, beside, and inside desks
 - in / out baskets,
 - plexiglass side attaching storage compartments, or
 - place lazy-susan rotating style trays.
4. Place simple plastic or wooden box bins beside or near the desk.
5. Attach handles. These may vary depending on individual need.

6. Mechanisms for easier access can include pivot systems, drawer slides, swing away, lockable and detachable in what ever direction is needed.
7. A hinged desk top can be used to meet space saving needs.
8. Under chair storage is useful.

CUSTOM STORAGE SOLUTIONS

School teams submitted illustrations demonstrating a number of unique approaches to meeting storage needs. Figures 3-1 to 3-4 illustrate the move from simple solutions to complex solutions.

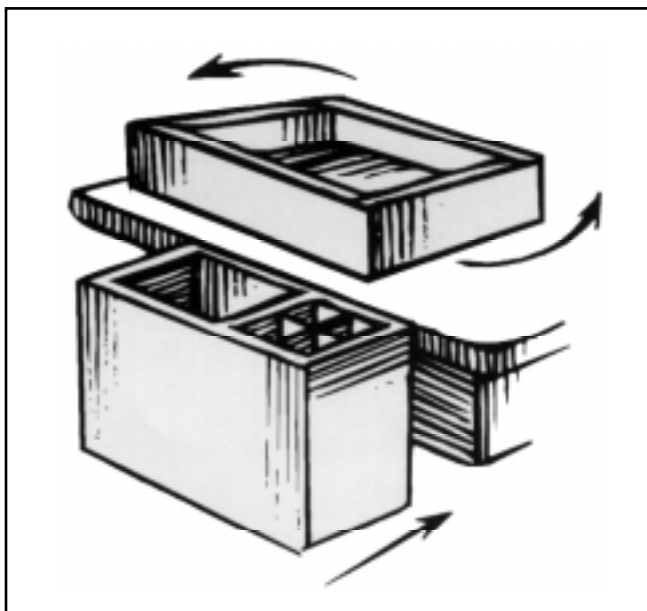
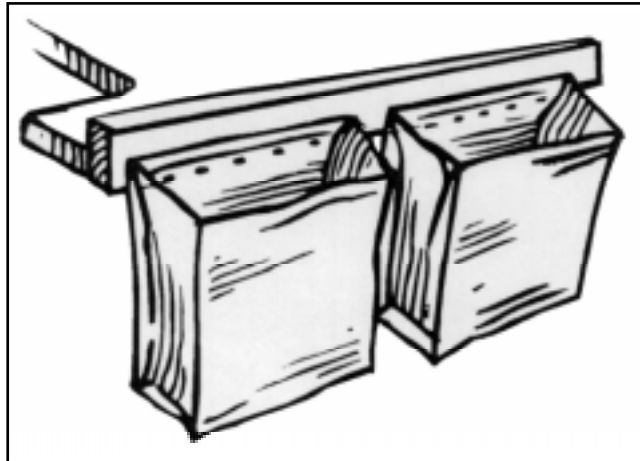

Figure 3-1 • Storage and Space Saving Ideas.

This illustration shows how to add features to a regular classroom desk. This sketch includes side mounted book and pencil boxes and an in/out bin with a rotating lazy-susan.

Figure 3-2 • Side Pocket Pouches on Commercial Desk



Side pouches are easy to install and a very inexpensive. These pouches can be used for a variety of storage needs.

Figure 3-3 • Customized Desktop with Drop Storage Area (School District No. 68 - Nanaimo)



This example illustrates the use of a regular classroom desk with a modification. The standard desktop has been replaced by a larger desktop and a drop storage area has been added. This customized desk is a simple storage solution for a student who can be seated at a regular classroom desk for all activities.

Figure 3-4 • Custom Design for a Student With Multiple Needs (Cathy Cavey, O.T. Child Development Centre, Abbotsford)

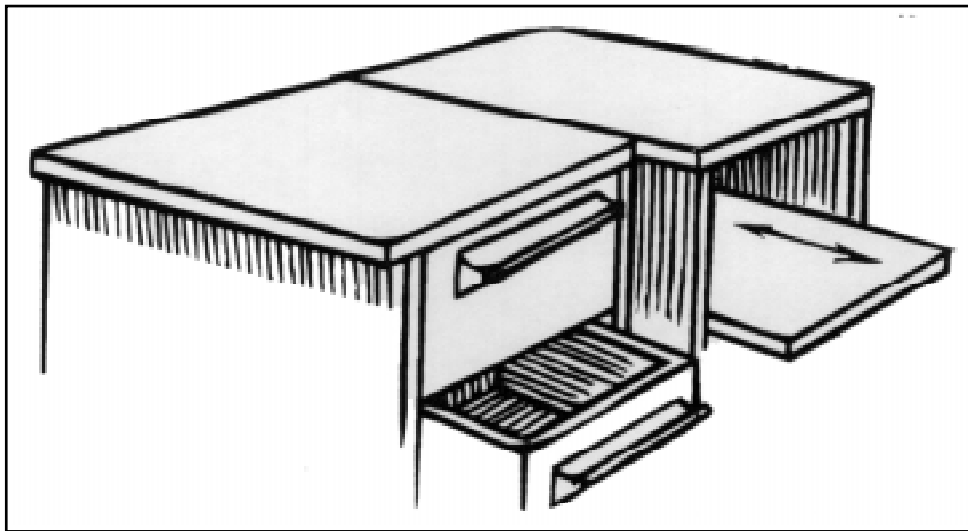

The side compartment is on lockable castors. The storage compartment can be fixed to the desk or detached and moved to another location (by the student if necessary). It has a locking mechanism for security. The drawer handles were customized to allow the student with poor fine motor control to open and close the drawers independently.

4. ACCOMMODATING COMPUTERS AND OTHER TECHNOLOGIES IN THE WORKSPACE

There are a number of considerations when designing workspace for a student using technology. This section provides a framework for looking at joysticks, wheelchair trays, the positioning of computers and other technologies, and the custom and commercial designs of computer tables.

JOYSTICKS ON POWER WHEELCHAIRS

Often the power wheelchair user discovers the joystick control will block access to the workstation. When encountering this problem, here are suggestions to overcome the problem.

1. Provide a custom “drop style” joystick mount.
2. Cut out or cut away the portion of the work station that hinders the joystick.
3. Fabricate a flip away or flip back arm, which can be positioned in place to provide forearm support.

Figure 4-1 • Cut Away Surface.
(School District No. 38 - Richmond)

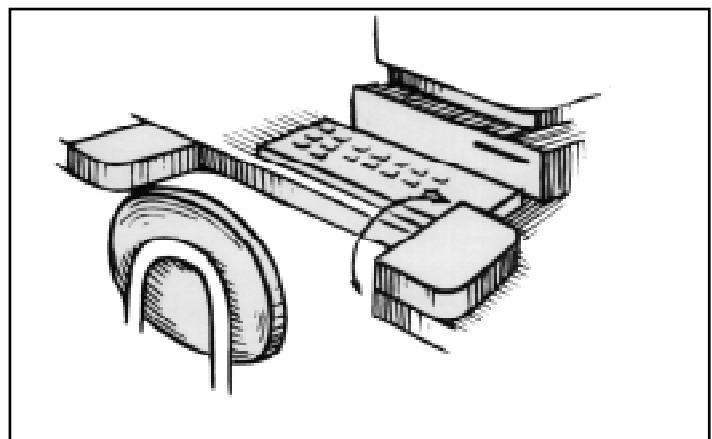

This example illustrates the “sideways style” cut away and will allow the wheelchair - joystick user access to a single station in a computer classroom.

Figure 4 - 2 • Custom Desktop with Easel Feature and Cut Away Support (School District No. 33 - Chilliwack)

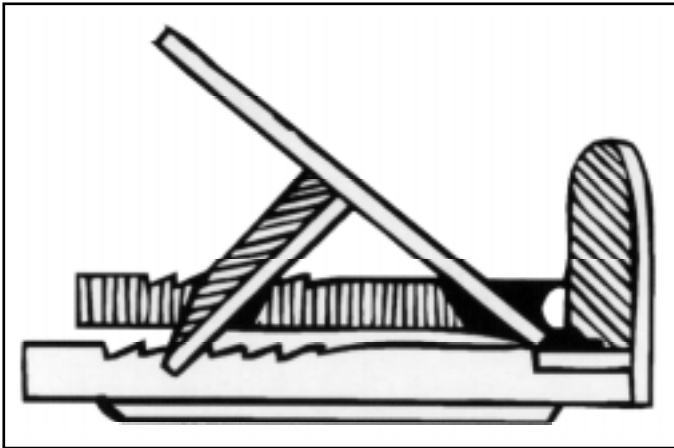

This custom desktop example illustrates a forearm support that will flip up in the forward position. Once the powerchair is in place and the joystick has been moved out of the way, the cut away can be lowered to provide the student with forearm support.

WHEELCHAIR TRAYS

A simple wheelchair tray may be preferred over a desk or workspace, particularly when mobility demands increase for a student moving from classroom to classroom in the course of a school day. In the design of the wheelchair tray, consideration must be given to

- the weight and type of technology that will be positioned on the tray,
- safety and security, and
- independent functioning.

Figure 4-3 • Custom “Sliding-Drawer” Wheelchair Tray (Sunny Hill Health Centre)

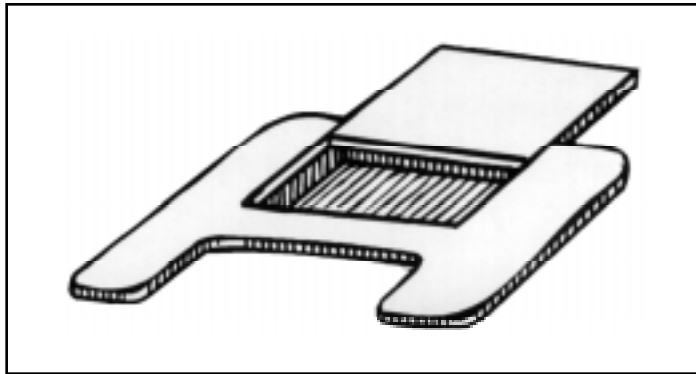

A wheelchair tray design may have a recessed drawer with a sliding cover allowing the tray top to be used for a variety of functions. Figure 4-3 illustrates the recessed drawer.

HINTS FOR TRANSPORTING TECHNOLOGY

Additional student equipment and supplies can be carried from classroom to classroom by

- back packs,
- side pouches and side bags,
- bags that fit under the wheelchair seat, or
- laptop carrying cases.

TECHNOLOGY AND SPACE SAVING IDEAS

Computer and office supply stores carry products that can meet the positioning and space saving demands for technology used in classroom settings as well as the work place. With new products coming to the market place so quickly, therapists and designers must strive to keep abreast of current products.

The following is a short list of possible solutions to technology positioning and space saving demands:

- monitor arms, with a variety of mounting possible (i.e. floor, desk, and wall mounts),
- risers for monitors with paper storage underneath or within each riser,
- paper positioners which may attach
 - on the side or front of the monitor
 - between the monitor and keyboard
 - on the desktop itself
- pull-out keyboards with mouse tray,
- keyboard arms, with floor mount or desk mount, and
- wrist rests for mice and keyboards. some height and angle adjustable to offer ergonomic support and stability for wrists.

Figure 4-4 • Keyboard and Mouse Tray

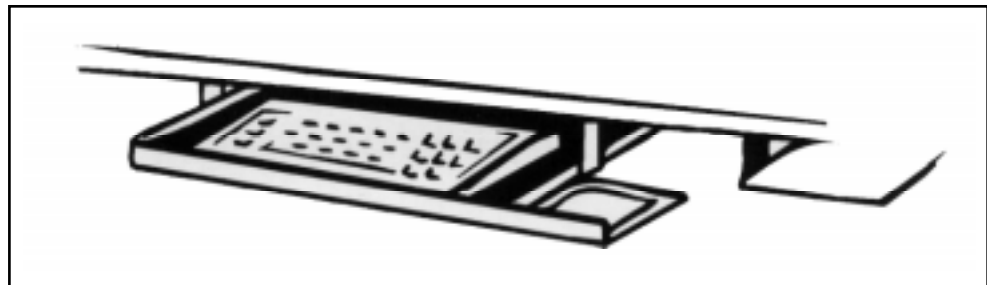
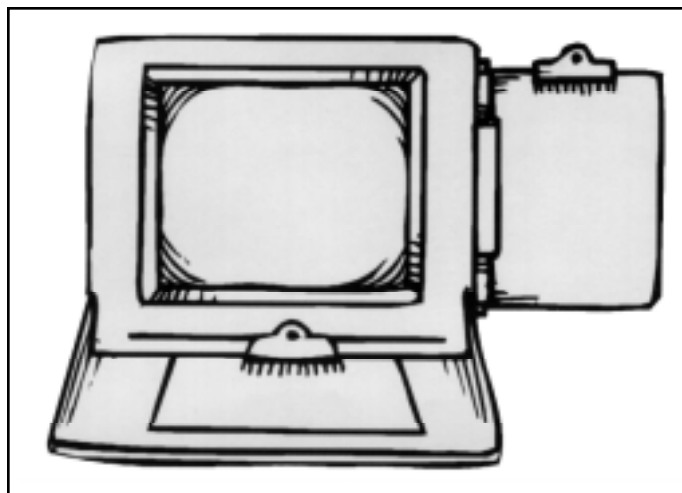

Figure 4-5 • Paper Positioner



If a student has visual perceptual difficulties and there is a need to place items in specific areas of the student's visual field, this portable easel illustrates how the workspace can be easily modified to meet the student's needs.

COMPUTER DESKS, WORK STATIONS, AND CUSTOM WORKSPACES

Many suppliers who fabricate computer desks will also customize. A list is contained in the Resource Section of this guide.

A few examples have been selected to illustrate the range of products available.

Whenever possible, school districts are encouraged to order height adjustable computer desks to meet a broad cross section of student needs.

There are many examples of functional computer desks and work stations available from computer stores. Many of these models include very creative designs. Making regular visits to these suppliers or receiving their catalogues will ensure that district and school staff keep pace with these products.

Figure 4-6 • Computer Work Stations

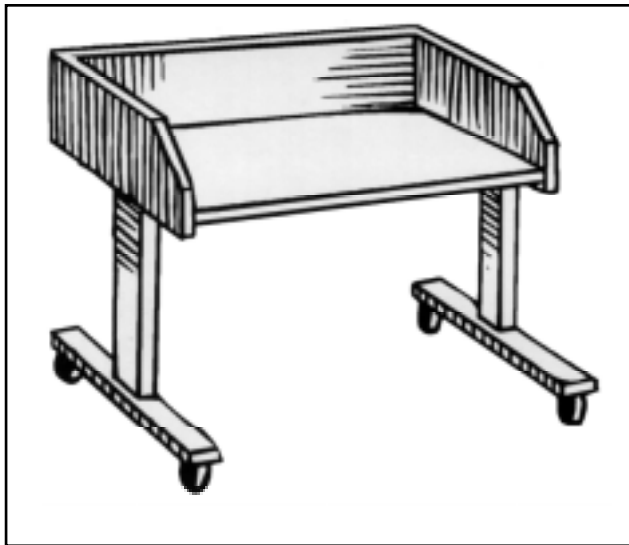

Commercially available workspaces may be the least intrusive alternative and should be viewed as an excellent option when considering workspaces options for computer use.

Figure 4-7 • Multi Adjustable Computer Work Station

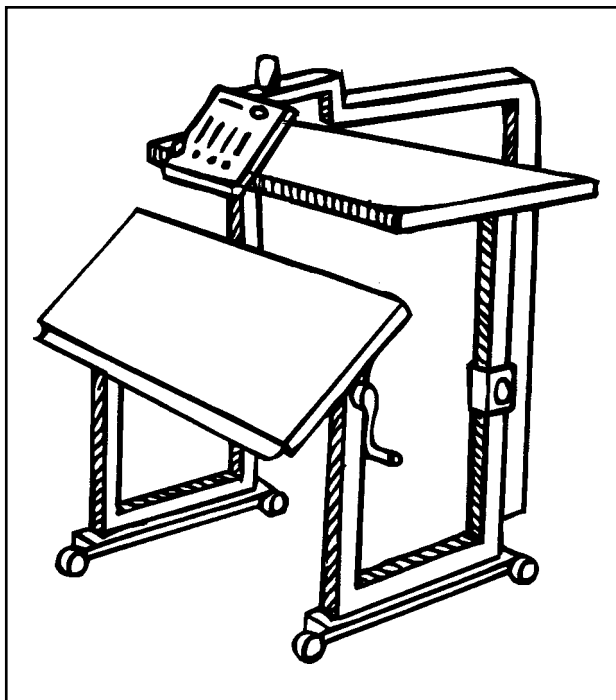

This computer station is adjustable with a number of variations in setup. It can support a number of technology components and will permit the components to be set up to meet a variety of unique needs dealing with vision, access, or placement.

5. ADAPTED WORKSPACES ACROSS THE SCHOOL

Planning for adapted workspaces in schools will often need to go beyond the considerations in a traditional classroom. Other settings in the school may present additional challenges for the planning team to consider. For example, the workspace which is planned for the regular class setting may not be functional in the science laboratory, home economics class, or other locations of the school. Plans will need to include adaptations to allow the student optimum participation in all activities of the educational program planned in the IEP. Lab stations, technology benches, kitchen facilities and other equipment may need adaptations to enhance the student's participation and learning. These adaptations should be planned in the same careful and collaborative manner as the regular classroom workspace and should include the teachers who work in these specialized areas.

While there are commercially available products to solve these challenges, in many cases schools will need to design and construct appropriate workspaces in these other settings around the school.

Figure 5-1 • A Carpenter's Bench

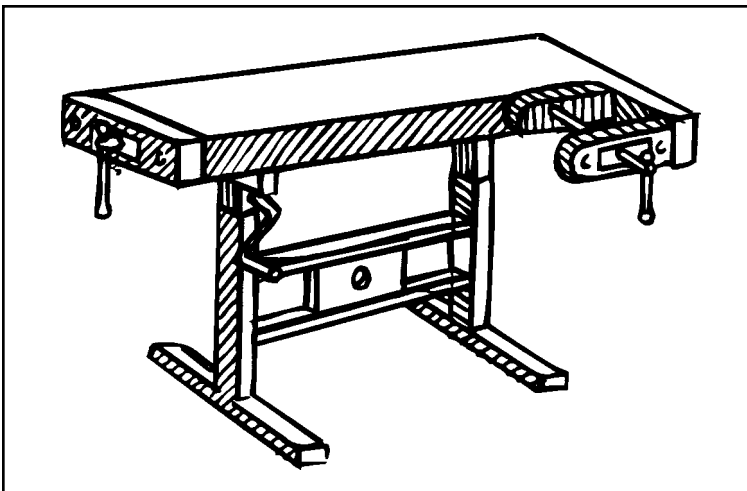

This is one example of an adapted workspace for technology education. The hand crank adjustment on this carpenter's bench can accommodate students who need to be seated or standing.

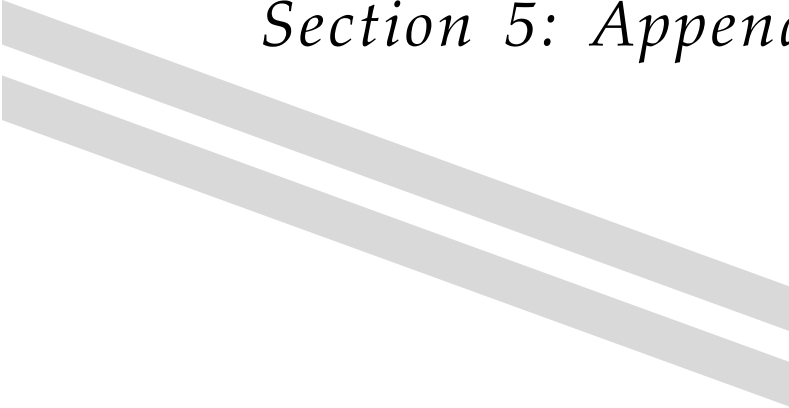

Section 5: Appendices

Appendix A

RESOURCES

MANUFACTURERS

Action Rehab Medical Inc.

- design and customize a system for student's complex positioning needs

Telephone: (604) 433-1544 Facsimile: (604) 433-1566
Location: Vancouver, BC. Canada

Able Generation (The)

- hand-make wooden chairs and desks built to be very adjustable

Telephone: (800) 875-2457 Facsimile: (207) 363-6558
Location: Portsmouth, New Hampshire, USA.

Belpar Industries

- custom build furniture for schools

Telephone: (604) 581-5291 Facsimile: (604) 581-3112
Location: Surrey, BC. Canada.

DaeSSy - Daedalus Technologies Inc.

- fabricate wheelchair mounting systems for technology
- provide highly adjustable wheelchair accessible workstations which hold heavy computer systems

Telephone: (604) 270-4605 Facsimile: (604) 244-8443
Location: Richmond, BC. Canada

E.B.M. Equity Beyond Mobility

- market a mobile, adjustable computer work station with a variety of options
- retrofit existing systems

Telephone: (517) 426-6327 Facsimile: (517) 426-7354.
Location: Gladwin, Minnesota, USA

Orca Office Furniture Manufacturing

- take custom orders and work with a school team early in the design stage

Telephone: (250) 746-7989 Facsimile: (250) 746-1089.
Location: Duncan, BC Canada

Pedersen Ergonomics Inc.

- manufacture and supply adjustable height tables for computers
- fill specialized requests and custom orders

Telephone: (519) 235-2725 Facsimile: (519) 235-3037.
Location: Exeter, Ont. Canada

Scandian Ergonomics

- British Columbia supplier for Ontario based Scandian Ergonomics

Telephone: (604) 856-1331 Facsimile: (604) 856-7509,
Location: Mt. Lehman, BC. Canada

Special Designs, Inc.

- provide custom equipment including adjustable wooden furniture and removable tilt-in space dolly.

Telephone: (908) 464-8825 Facsimile: (908) 464-8251.

Location: Berkeley Heights, New Jersey. USA

Willow Pond Tools Inc.

- offer a wide range of adapted workplace furniture

Telephone: (603) 485-2321 Facsimile: (603) 485-2303.

Location: Pembroke, New Hampshire. USA

SUPPLIERS

For a comprehensive list of suppliers in the United States, a resource which includes brief descriptors and measurements, request:

Adjustable Tables, Adjustable Workstations for the Ergonomic Home, Office, and Classroom. A Resource Guide.

Source: Living and Learning Resource Centre. Lansing MI
Telephone: (517) 487-0883 Facsimile: (517) 224-0957

Chairlines

- desk top easels and ergonomic office and computer supply items

Telephone: (604) 736-7623 Facsimile: (604) 736-7620.

Location: Vancouver, BC, Canada

Insight Media Centre

- products such as multimedia workstations, height adjustable and cabinet styles work stations (from Bretford Canada Ltd.)

Telephone: (604) 581-2420 Facsimile: (604) 581-2420
Location: Surrey, BC, Canada

Free To Be

- adaptable equipment which fits on tables, beds, etc.

Telephone: (604) 267-0831 Facsimile: (604) 267-0836
Location: Vancouver, BC, Canada

D.J. Technical

- custom mounting and special order workspace designs

Telephone: (604) 436-2694 Facsimile: (604) 436-2695
Location: Vancouver, BC, Canada

Legacy (Rifton Products)

- wooden adjustable chairs, tables, etc.

Telephone: 1(800) 667-6629 Facsimile: (604) 253-7193
(Rifton Products in BC)

Within the Local Community

remember to check:

- hardware and building supply stores
- office and computer supply stores
- music stores
- photography stores
- plastics-custom work businesses
- recreational vehicle supply stores

CATALOGUES

Medical suppliers and school suppliers have ready-made items for purchase. Often these catalogues include items useful in adapting workspaces.

1. Ableware (Maddak)

- variety of reading stands, etc.

Telephone: (201) 678-7600 Facsimile: (201) 305-0841

2. Achievement Basic Products

- adjustable height positioning chairs, standers, etc.

Telephone: 1-800-450-8554 Facsimile: (716) 298-4701

3. Flaghouse

- large variety of special education materials

Telephone: 1-800-265-6900 Facsimile: 1-800-265-6922

4. Moyers

- school and office furniture, etc.

Telephone: 1-800-268-0592 Facsimile: (416) 749-7846

Banbury Cross - in British Columbia

Telephone: 1-800-665-0090 Facsimile: (604) 543-8408

5. North Coast

- desktop and computer forearm aids, etc.

Telephone: 1-800-821-9319 Facsimile: (408) 283-1950

6. Physio / E.R.P.

- crank style height adjustable work stations, varieties of desk tops etc.

Telephone: 1-800-361-3537 Facsimile: (514) 687-8035

7. Rifton, (Rifton, NY, USA),

- wooden adjustable chairs, tables, etc.

Telephone: 1-800-374-3866 Facsimile: 1-800-336-5948

Rifton products in British Columbia - Legacy

Telephone: 1-800-667-6629 Facsimile: (604) 253-7193

8. Sammons Preston

- Sammons and Preston have a combined catalogue for 1996 catalogue
- tumble forms, adjustable positioning chairs and tables, computer equipment adaptations

Telephone: 1-800-665-9200 Facsimile: (613)392-4139

APPENDIX C

Adapted Workspaces Planning Form

This form should be completed by the project leader coordinating the development of the adapted workspace. You are encouraged to identify and invite all those involved with the student who will play a key role in the design of an appropriate workspace.

Student: _____ School: _____

Meeting date: _____ Project Leader: _____

General Information

Team members involved with this student and attending the meeting.		
Name:	Role/Position:	Telephone:

Planning Discussion

For each of the following attributes, first describe the student's level of ability. Second, record the discussion with respect to the *Implications for Workspace and its Location*.

- Physical ability
- Mobility and seating
- Motor abilities and constraints
- Vision
- Hearing
- Technology

Physical ability: (mobility, movement, posture, etc.)

Implications for Workspace: _____

APPENDIX C

AWS Planning Form

...2

Mobility and seating:
<i>Implications for Workspace:</i> _____
Motor abilities and constraints:
<i>Implications for Workspace:</i> _____
Vision:
<i>Implications for Workspace and its Location:</i> _____
Hearing:
<i>Implications for Workspace and its Location:</i> _____

APPENDIX C

AWS Planning Form

... 3

Educational Program Considerations:

Student's Educational Goals

Classroom Curricular Demands (cooperative learning, other group work, lab work, courses in other classrooms).

Student will transition to:

